

SOLID PLASTIC (HDPE)

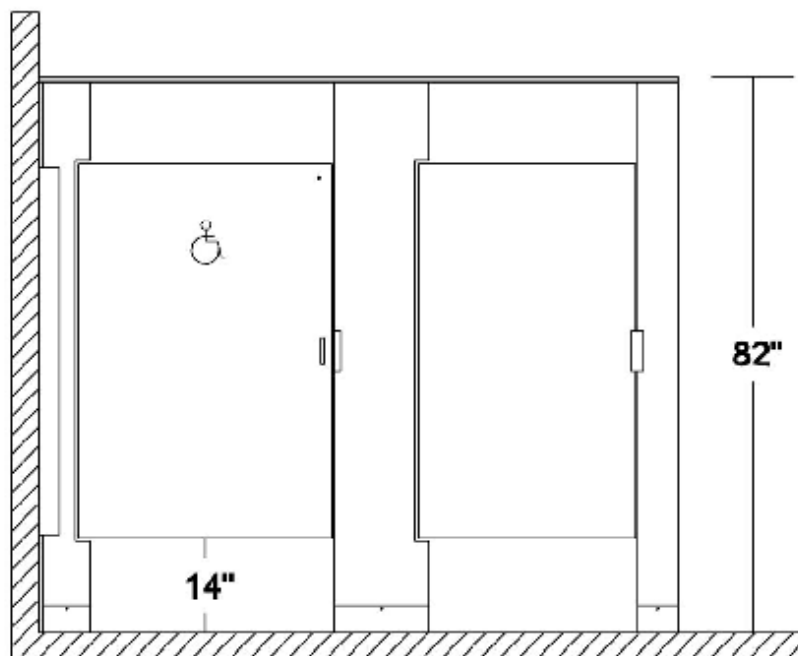

INSTALLATION INSTRUCTIONS

Factory Provided



1/4" Washer

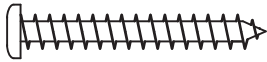

#14 x 1-1/2" Screw

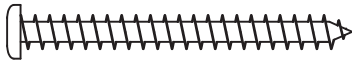

#14 x 2" Screw



#14 Plastic Anchor



#10-24 x 15/16" Shoulder Screw

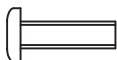

#10-24 x 5/8" Barrel Nut

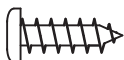

#14 x 3/4" Screw



#10-24 x 1-3/8" Shoulder Screw



#10 x 3/4" Screw



#10 x 1" Screw

Recommended Tools Installer Provided

- **Tape Measure**
- **Level**
- **Hammer**
- **Pencil / Chalk Line**
- **Miter Saw or Hand Saw w/ Metal Blade**
- **Portable Drill**
- **Masonry (Hammer) Drill**
- **#2 Phillips Bit / Screw Driver**
- **1/8" Drill Bit (Integral Hinge Only)**
- **5/32" or 3/16" Drill Bit**
- **1/4" Drill Bit**
- **5/16" Masonry Drill Bit**
- **Drywall Cart**
- **14" Tall Support Block (For Standard Panel & Door Height)**
- **T-27 Security Torx Bit (Factory Provided)**
- **T-7 Security Torx Bit (Factory Provided - Integral Hinge Only)**

Understanding Your Factory Drawings

Step 1 - Typical Layout

1. Follow all general layout details as shown in DETAIL-1.1
2. Use the drawings provided to mark the centerline of the pilasters on floor. (Snap a chalk line if needed)
(The distance from the wall is approximately 1/2" less than the overall dimension shown on the drawing)
3. Use a pencil and mark the centerlines of the pilasters & panels on the back & side walls.
4. Double check your layout prior to proceeding
5. If any changes need to be made to your layout - Make them now
6. Proceed to Step 2

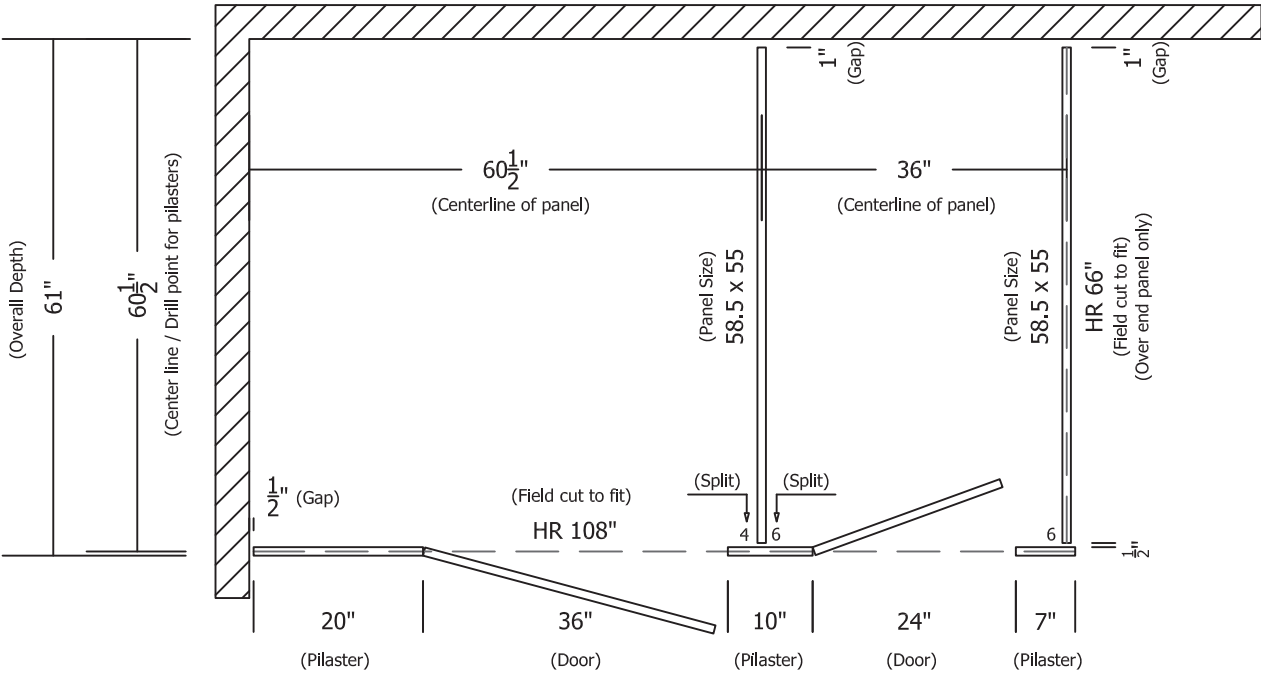

DETAIL-1.1

Step 2 - Pilaster Shoe Install

1. Follow all general layout details as shown in DETAIL-2.1
2. Use the drawings provided and begin your layout from side wall. (Follow your center line from Step 1)
(All pilaster dimensions shown on drawing are from edge to edge / Shoe position is located by inside of the shoe)
3. Align inside edge of shoe with the gap distance shown on drawing
4. Mark the slots inside the shoe with a pencil (Make sure you stay on your center line)
5. Continue layout across room following the same procedure.
6. Double check your layout prior to proceeding
7. Remove the shoes and drill holes using a 5/16" masonry bit
8. Insert #14 plastic anchors into the holes and hammer in securely
9. Place the shoes over the holes and fasten to floor using the 1/4" washer and #14 x 2" screw (DETAIL-2.2)
10. Proceed to Step 3

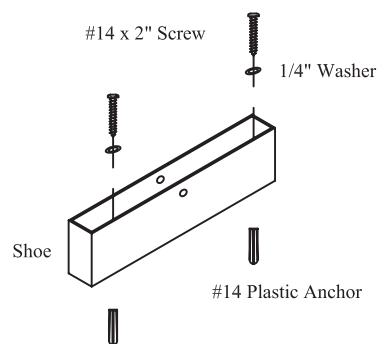
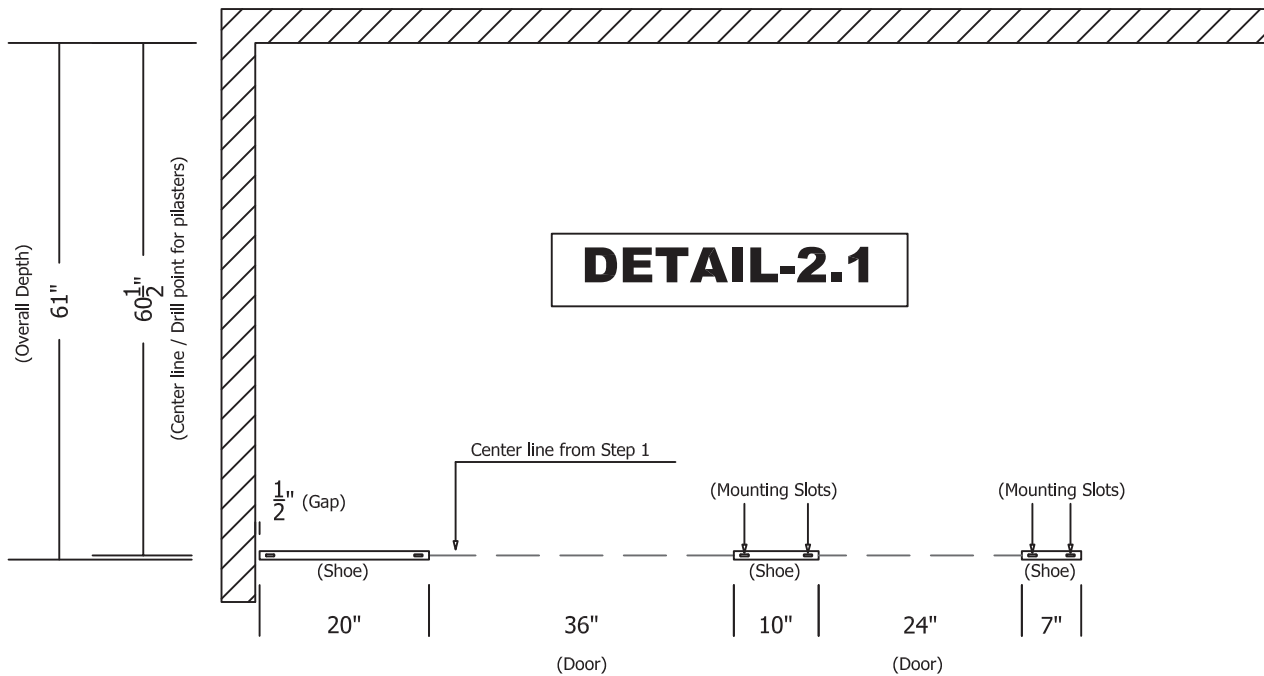

Floor to Ceiling Pilaster Shoe Install

1. Use the job specific drawings provided for exact location of pilasters.
2. Use required floor shoe as template and mark slots on floor.
3. Drill 5/16" holes and insert #14 plastic floor anchors.
4. Place shoe over holes and secure using washer and #14-2" torx screw.
5. Repeat similar layout process at ceiling using stainless angle bracket as template.
6. Secure angle bracket to ceiling using washer and #14-2" torx screw.
7. Slide required ceiling shoe onto pilaster and place pilaster into floor shoe.
8. Fasten pilaster to installed ceiling angle bracket with #14 X 3/4" torx screws.
9. Slide shoe up to conceal angle bracket and secure using #10 x 3/4" torx screw.
10. Fasten pilaster to floor shoe using sex bolt.

CEILING MOUNT (AS SHOWN) (4" HIGH SHOE w/ OFFSETS AT CEILING)

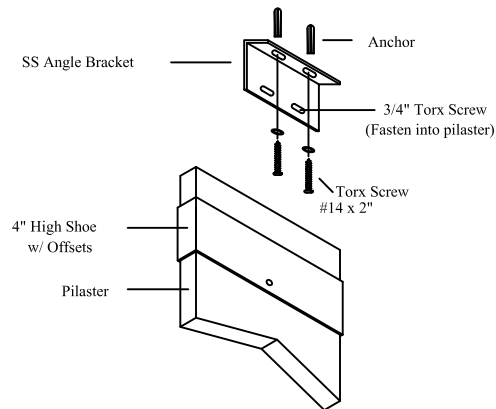

FLOOR MOUNT (AS SHOWN) (STANDARD 3" HIGH SHOE AT FLOOR)

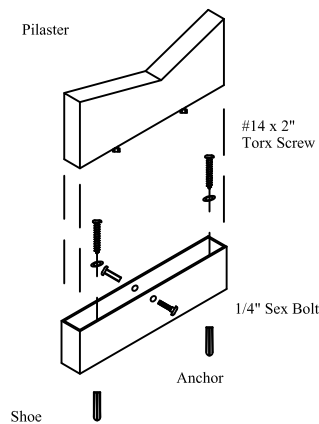

Step 3 - Wall Bracket Install

1. Follow all general layout details as shown in DETAIL-3.1
2. Use the drawings provided and begin your layout from side wall.
(Note: All stall widths shown on drawing reference centerline of panels / wall brackets)
3. Locate center line of first wall bracket. Mark this location at 18", 41.5" and 65" off finished floor (DETAIL 3.2)
4. Use a wall bracket as a template and mark mounting hole locations (All 3 brackets should remain plum)
5. Continue layout across room following the same procedure.
6. Double check your layout prior to proceeding
7. Drill holes using a 5/16" masonry bit
8. Insert #14 plastic anchors into the holes and hammer in securely
9. Place the single ear or double ear wall bracket over the holes and fasten to wall using #14 x 2" screw
10. Proceed to Step 4

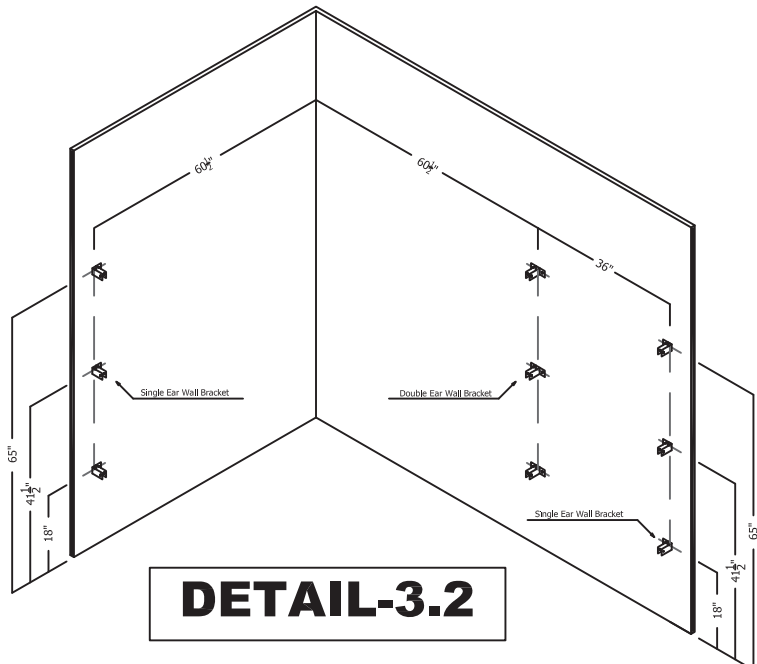
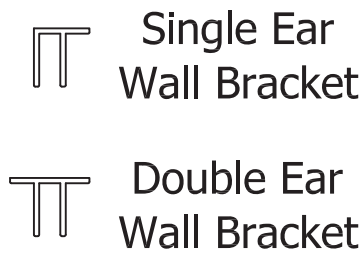
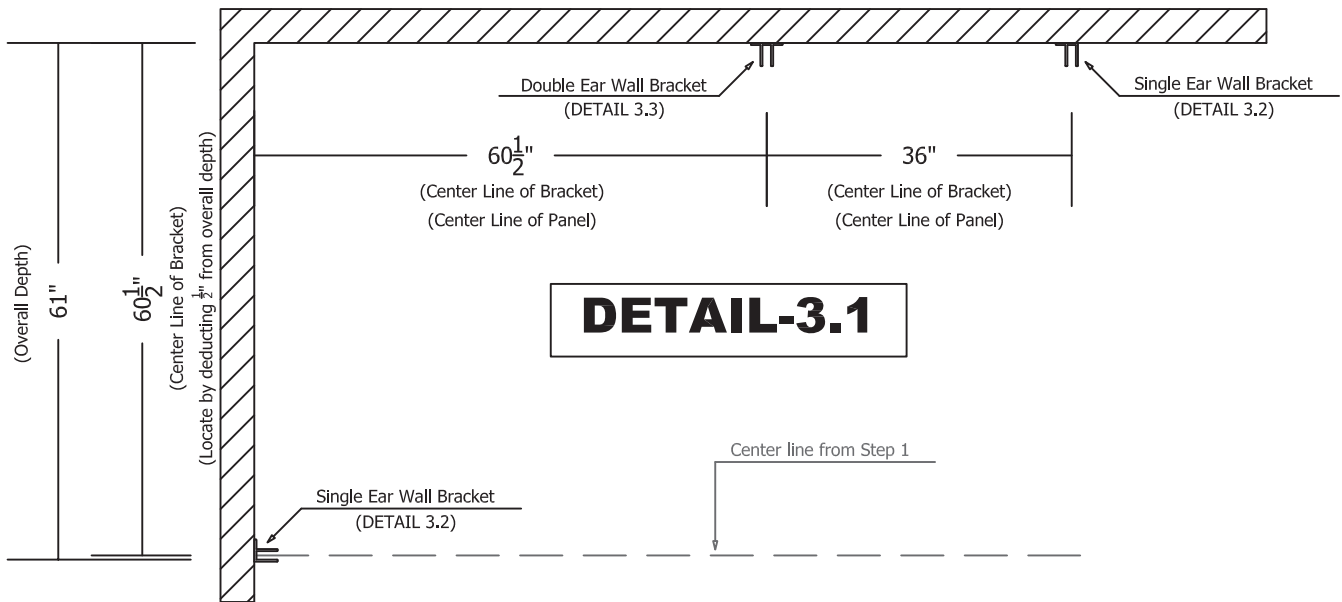

Step 3 - Continuous SS Wall Bracket Install

1. Follow all general layout details as shown in DETAIL-3.1
2. Use the drawings provided and begin your layout from side wall.
(Note: All stall widths shown on drawing reference centerline of panels / wall brackets)
3. Locate center line of bracket. Mark this location at 14.5" or 68.5" off finished floor (This is either bottom or top of bracket)
4. Use a wall angle bracket as a template and mark mounting hole locations.
5. Be sure to HOLD 1" clear between each angle to allow for panel to be installed later.
6. Continue layout across room following the same procedure.
7. Drill holes using a 5/16" masonry bit
8. Insert #14 plastic anchors into the holes and hammer in securely
9. Place the single ear or double ear wall bracket over the holes and fasten to wall using #14 x 2" screw
10. Proceed to Step 4

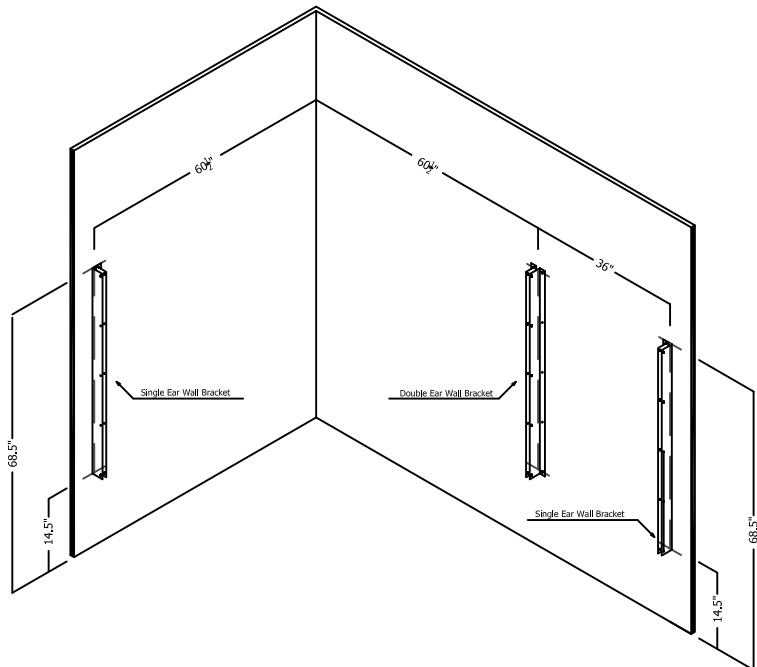
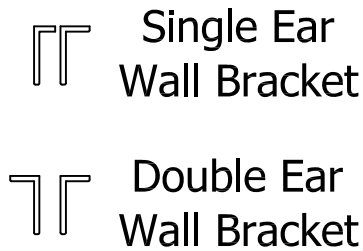
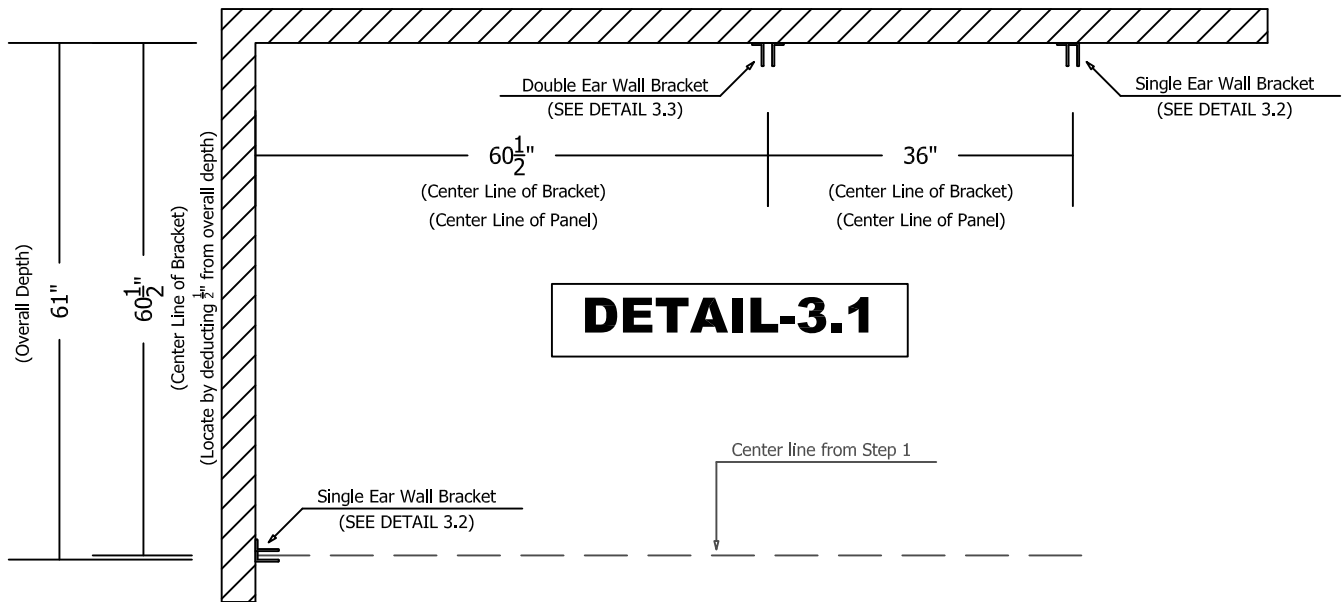

Continuous SS Wall Brackets - DETAILS

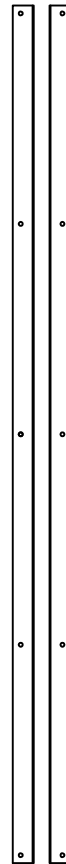
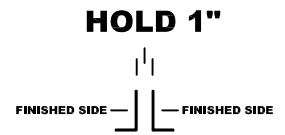
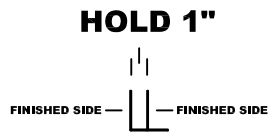
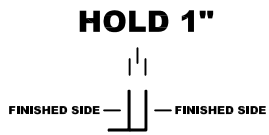

SINGLE EAR (LEFT)
2 piece bracket
(DETAIL 3.2)

SINGLE EAR (RIGHT)
2 piece bracket
(DETAIL 3.2)

DOUBLE EAR
2 piece bracket
(DETAIL 3.3)

Step 4 - Panel Install

1. Follow all general layout details as shown in DETAIL-4.1
2. Position the 14" support block (by installer) halfway between the back wall and pilaster shoe
3. Place divider panel onto support block (Adjust panel and support as needed to properly balance panel)
4. Carefully slide the panel into the wall bracket until you achieve a 1" gap from edge of panel to back wall
5. Plumb and level the panel
6. Drill 1/4" hole through panel using the wall bracket as a guide
7. Secure panel to bracket using thru-bolts provided (#10-24 x 15/16" machine screw & #10-24 x 5/8" barrel nut)
8. Continue process for each wall bracket until panel is secure
9. Proceed to Step 5

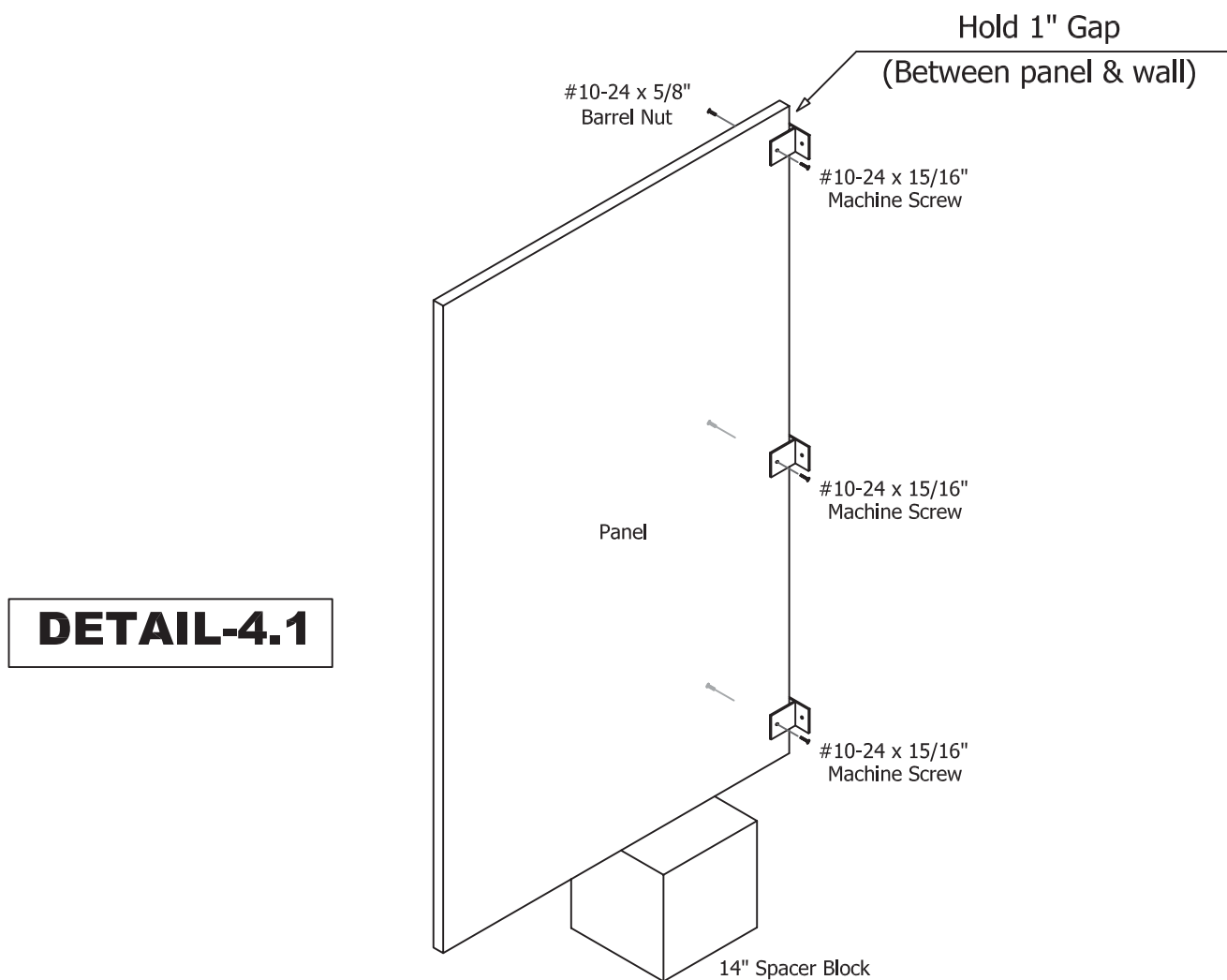

Step 5 - Pilaster Install

1. Follow all general layout details as shown in DETAIL-5.1 & DETAIL-5.2
2. Use the drawings provided and locate the required pilaster for install
3. Measure the required Split (also referred to as centerline of U-bracket) on backside of pilaster as shown in DETAIL-5.1
4. Using this center line and U-bracket as a template, mark mounting locations at 18", 41.5" and 65" off finished floor
4. Predrill 3/16" holes approximately 1/2" deep into back of pilaster (DO NOT DRILL THROUGH FACE OF MATERIAL)
6. Fasten U-brackets to pilaster using #14 x 3/4" Screws
7. Carefully place pilaster into shoe and align U-brackets until you achieve a 1/2" gap from edge of panel to back of pilaster
8. Plum and level pilaster
9. Drill 1/4" hole through panel using the U-bracket as a guide (DETAIL-5.2)
10. Secure panel to U-bracket using thru-bolts provided (#10-24 x 15/16" machine screw & #10-24 x 5/8" barrel nut)
11. Continue process for each U-bracket until panel and pilaster are secure
12. Lastly, secure pilaster to floor by drilling 1/4" hole through center hole in shoe and secure with thru-bolt
13. Remove temporary 14" spacer block from underside of panel
14. Repeat Step 4 followed by 5 until all panel / pilaster components are installed

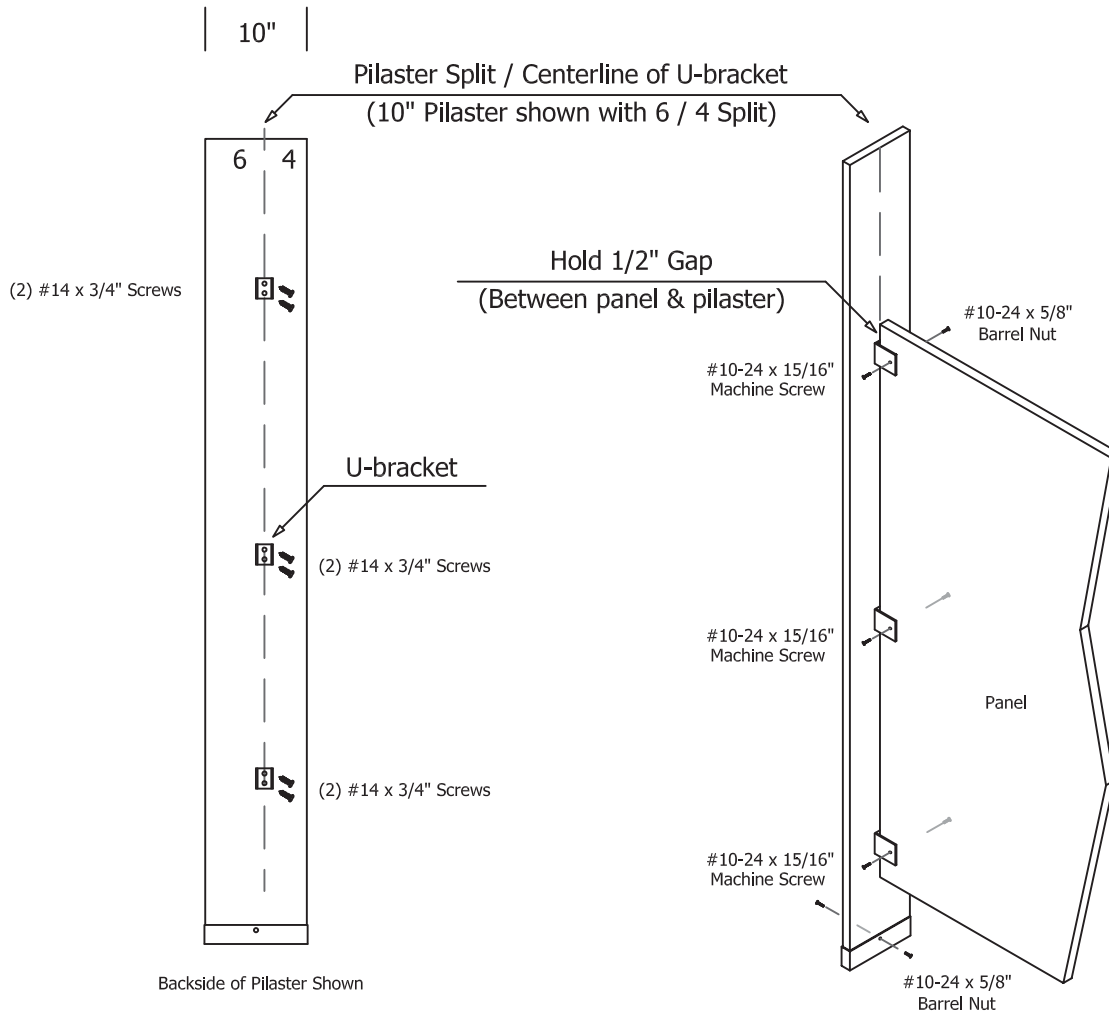

DETAIL-5.1

DETAIL-5.2

Step 5 - Pilaster Install w/ Continuous Brackets

1. Follow all general layout details as shown in DETAIL-5.1 & DETAIL-5.2
2. Use the drawings provided and locate the required pilaster for install
3. Measure the required Split (also referred to as centerline of U-bracket) on backside of pilaster as shown in DETAIL-5.1
4. Using this center line and U-bracket as a template, mark mounting locations
4. Predrill 3/16" holes approximately 1/2" deep into back of pilaster (DO NOT DRILL THROUGH FACE OF MATERIAL)
6. Fasten U-bracket to pilaster using #14 x 3/4" Screws
7. Carefully place pilaster into shoe and align U-brackets until you achieve a 1/2" gap from edge of panel to back of pilaster
8. Plum and level pilaster
9. Drill 1/4" hole through panel using the U-bracket as a guide (DETAIL-5.2)
10. Secure panel to U-bracket using thru-bolts provided (#10-24 x 15/16" machine screw & #10-24 x 5/8" barrel nut)
11. Continue process for each hole in U-bracket until panel and pilaster are secure
12. Lastly, secure pilaster to floor by drilling 1/4" hole through center hole in shoe and secure with thru-bolt
13. Remove temporary 14" spacer block from underside of panel
14. Repeat Step 4 followed by 5 until all panel / pilaster components are installed

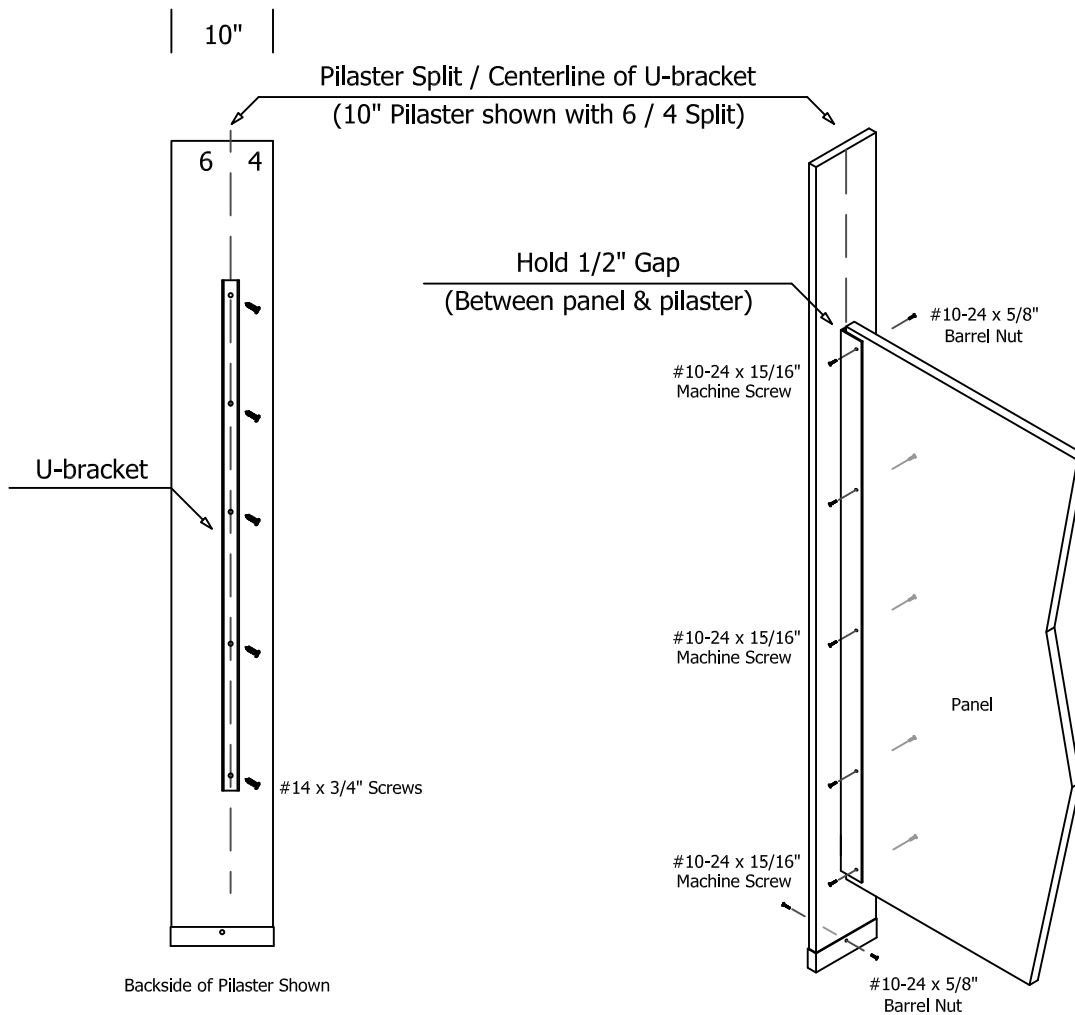

DETAIL-5.1

DETAIL-5.2

Step 6 - HEADRAIL INSTALL

1. Follow all general layout details as shown in DETAIL-6.1
2. Use the drawings provided and locate the required lengths of headrail for install
(Note: All headrail sizes noted on drawing are slightly oversized and will require a field cut by installer)
3. Start at side wall and position required headrail over top of pilasters
4. Continue to dryfit all headrail, Ensuring all seams exist over a pilaster (Cut headrail if required)
5. Locate headrail bracket and place under headrail at side wall connection.
6. Use bracket as a template and mark hole locations on wall.
7. Remove bracket and carefully drill 5/16" hole into wall.
8. Insert #14 plastic anchors and fasten bracket to wall using #14 x 2" screw
9. Realign and secure headrail to bracket by predrilling 3/16" hole and fastening from each side using #14 x 3/4" screws
10. Now locate the centerline on backside of pilaster and predrill 3/16" hole through headrail and into pilaster.
11. Secure headrail to pilaster using #14 x 3/4" screw
12. Continue process for each pilaster making sure all door openings remain true and plum.
13. If your factory layout requires a return (or) crossbracing headrail - Follow steps below
14. Align headrail bracket perpendicular to backside of pilaster and fasten using #14 x 3/4" screws
15. Align headrail bracket at back wall and fasten using #14 x 2" screws
16. Cut headrail to proper size and install as described above.
17. Lastly, insert plastic headrail end cap into any exposed outside corner.

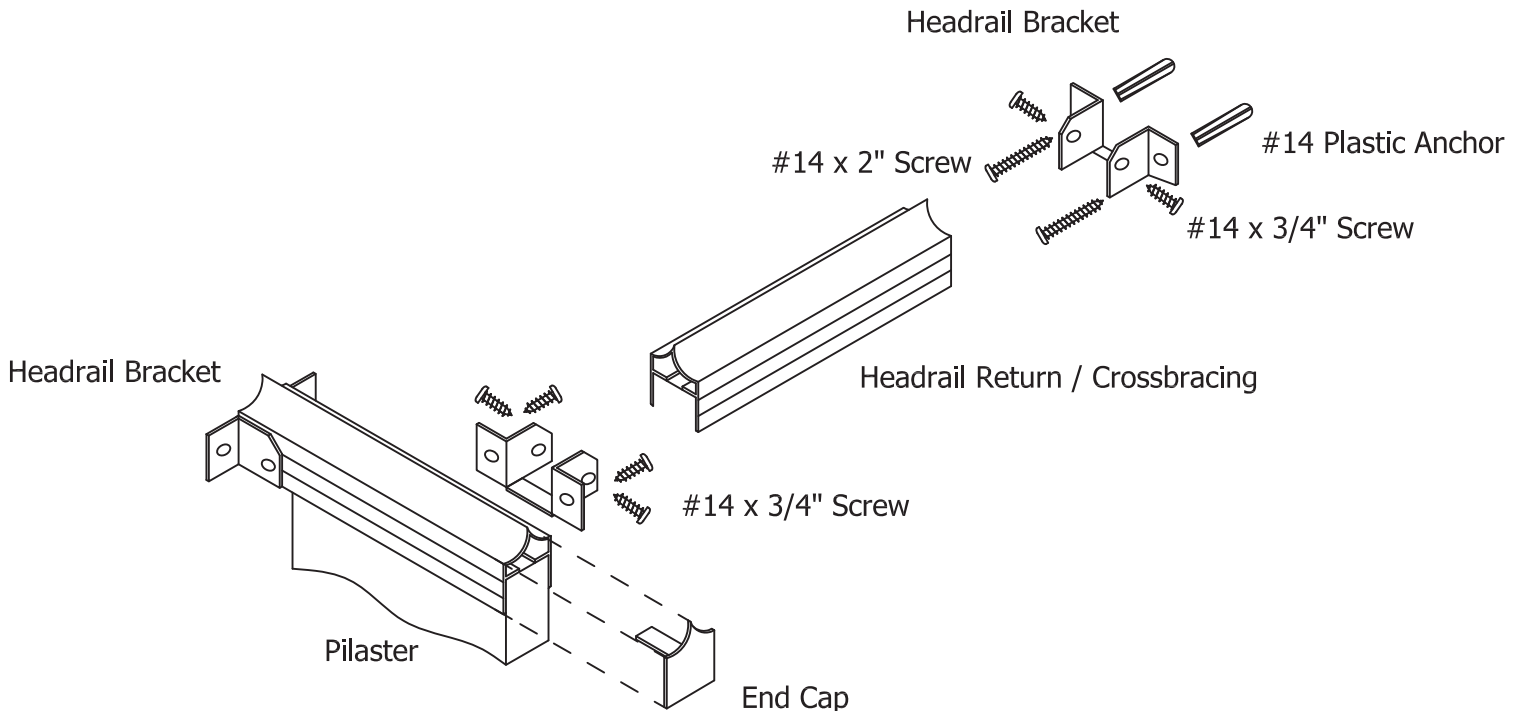

DETAIL-6.1

ST/ST Hinge

The ST/ST 54 1/2" hinge is surface mounted and fastened with 3/4" torx head screws. The hinges are set for either 15° opening or set to close. Doors 30" or over require the doors set to closed position, so whether they are in-swing or out-swing doors the hinge set to close must be used. To mount, measure up from the bottom of the pilaster 14 1/2" and mark; this will be the location of the bottom of the hinge (See EXP. A). Measure in from the edge of the pilaster toward the center 1 7/16" and make a mark parallel with the pilaster edge, place your hinge against the pilaster on these two marks and mark the pre-drilled hole locations from the hinge onto the pilaster. Remove the hinge and drill a 5/32" hole 1/2" deep into the pilaster on the mark. Replace the hinge and secure with a 3/4" torx head screw. Pilot drill the rest of the holes on the pilaster side of the hinge and secure. Set your door 14" above the finished floor, with a 1/8" gap between the door and pilaster, secure hinge to door in same fashion as above.

(EXP A.)

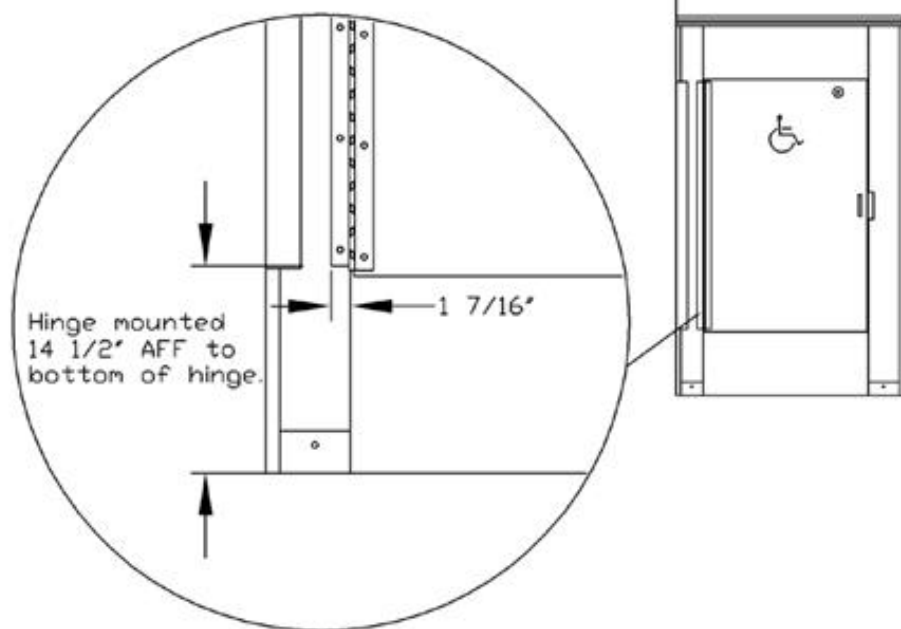
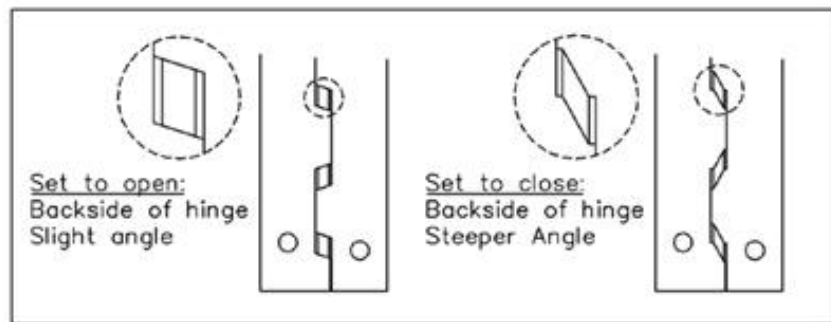

When hinges are installed, the hinge will have a 1/4" offset when in the rest position. This allows for the door to lift when opened, allowing gravity to return the door to the set position.

Note: Hinges are provided for H/C stalls to return to the closed position. Standard in-swing stalls are supplied to return to 15 degrees open. Hinges are not field adjustable.

Integral Door Hinge Install

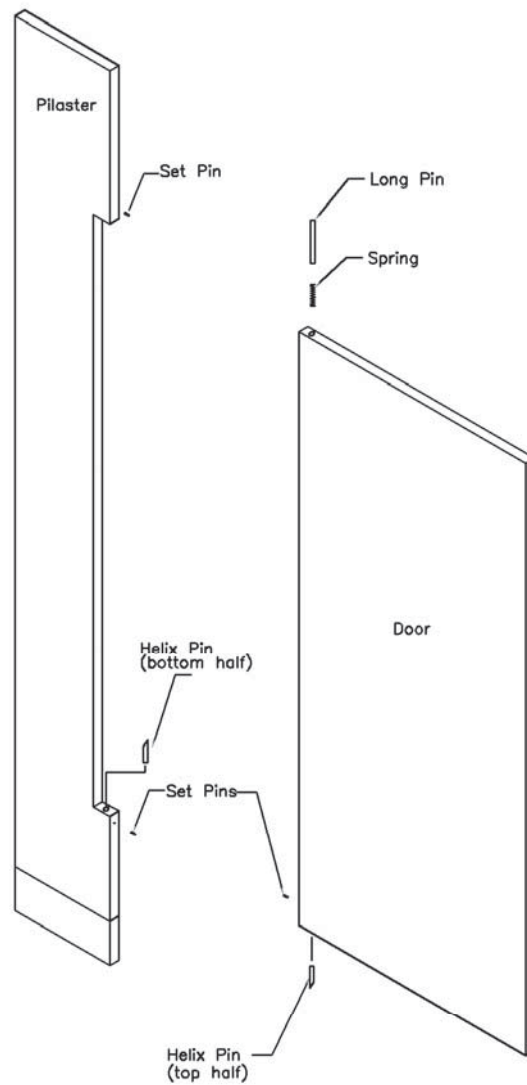

1. Insert the top half of the self closing helix pin into the bottom of the door with the slanted edge inline with the door until there is 1/2" of the steel pin showing. Drill 1/8" hole by 2" deep through the nylon section of the helix.
2. Insert the set pin to hold the helix pin in position.
3. Insert the bottom half of the helix pin into the pilaster leaving about 1 1/4" exposed.
4. Set the angle of the slanted surface to the desired angle of the door at rest. drill a 1/8" hole through the nylon section of the helix pin.
5. Insert the set pin to hold the helix pin in position.
6. Place the spring and the long pin into the top hole of the door.
7. Mount the door on the self closing pin and align the top hinge with the top hole in the pilaster. Slide the door into position until the spring locates the pin into the pilaster.

Wrap Around Hinge

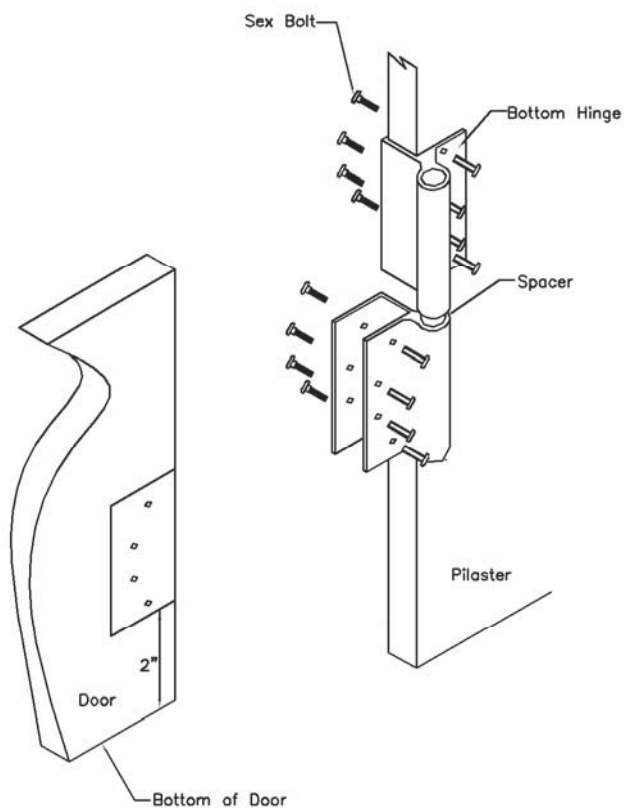
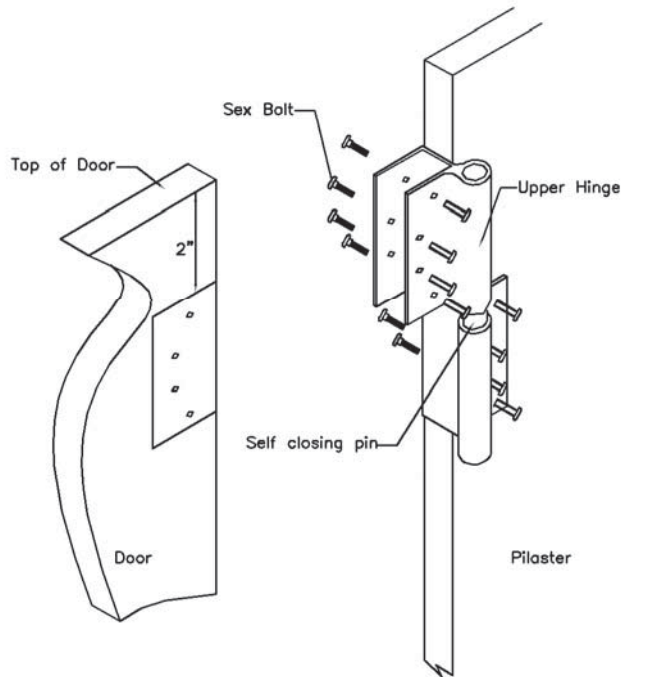

(WRAP AROUND HINGE - LH-IN / RH-OUT)

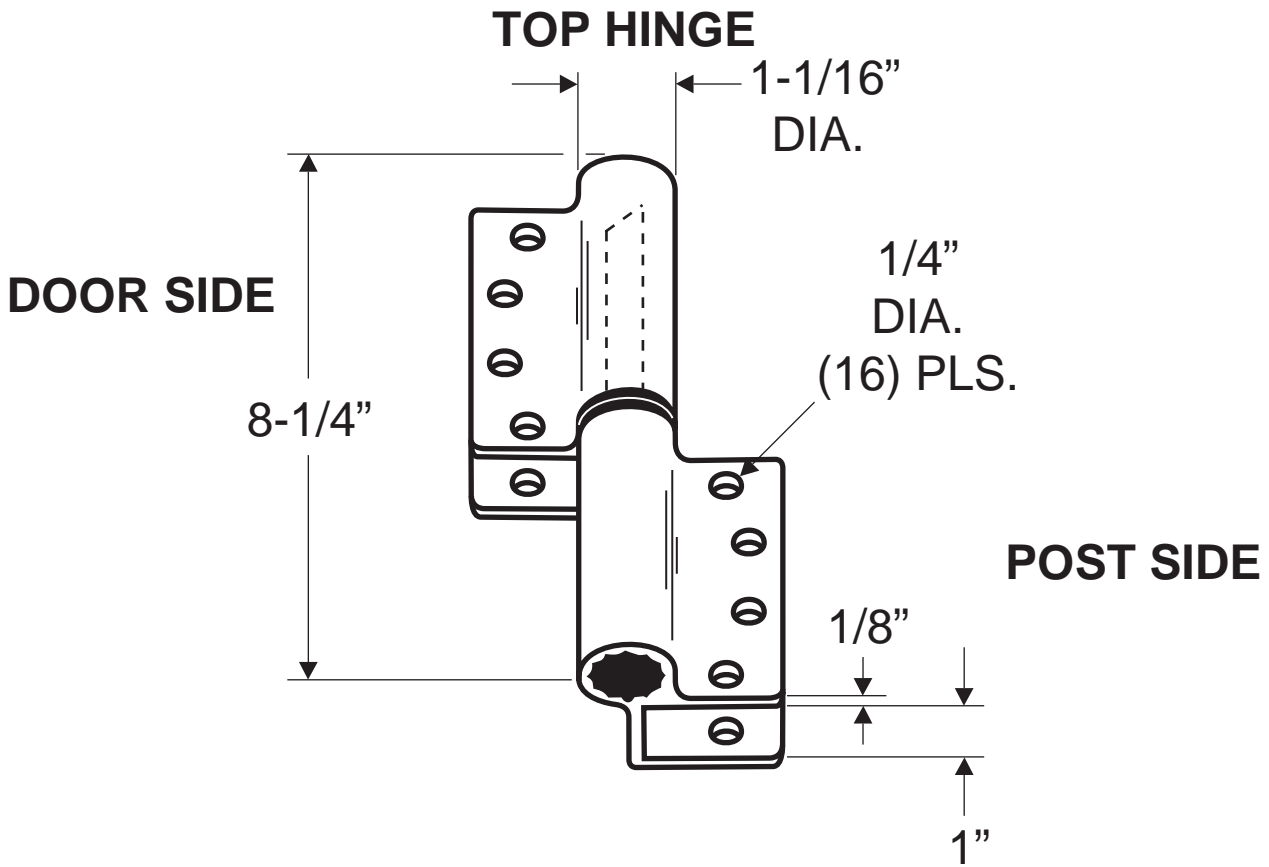

*** ALLOW 1/2" SPACE FOR INSTALLATION**

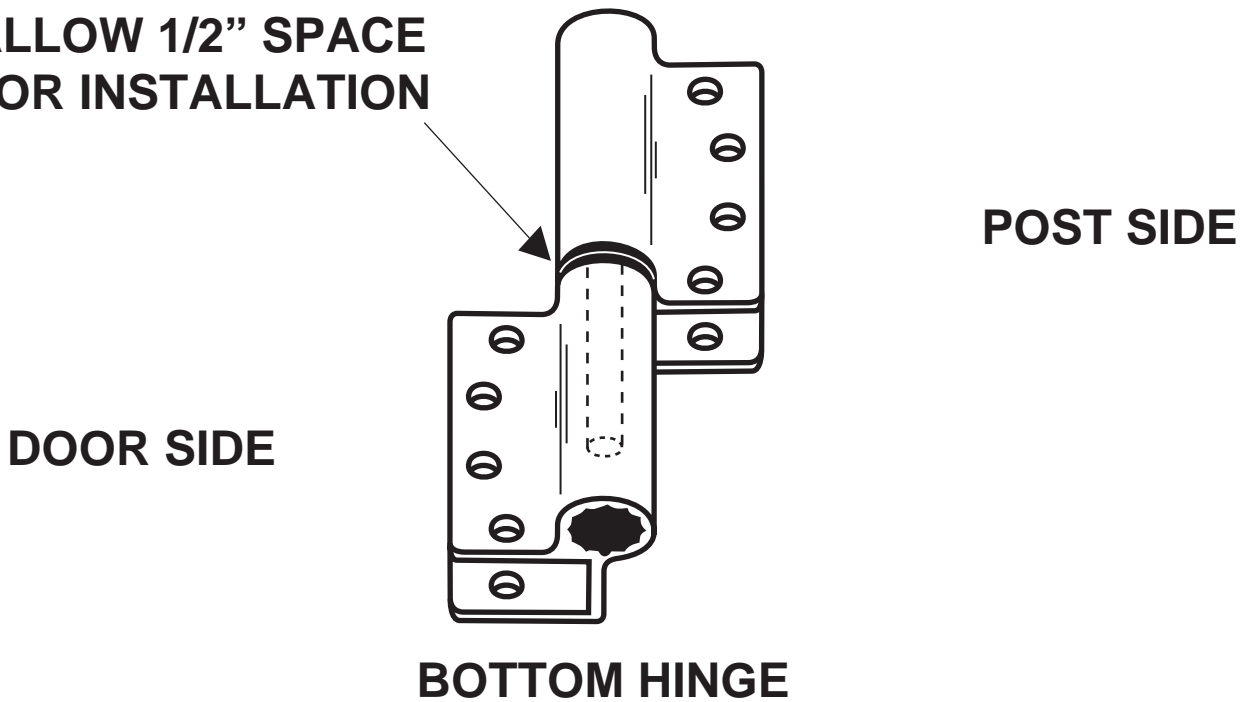

(WRAP AROUND HINGE - RH-IN / LH-OUT)

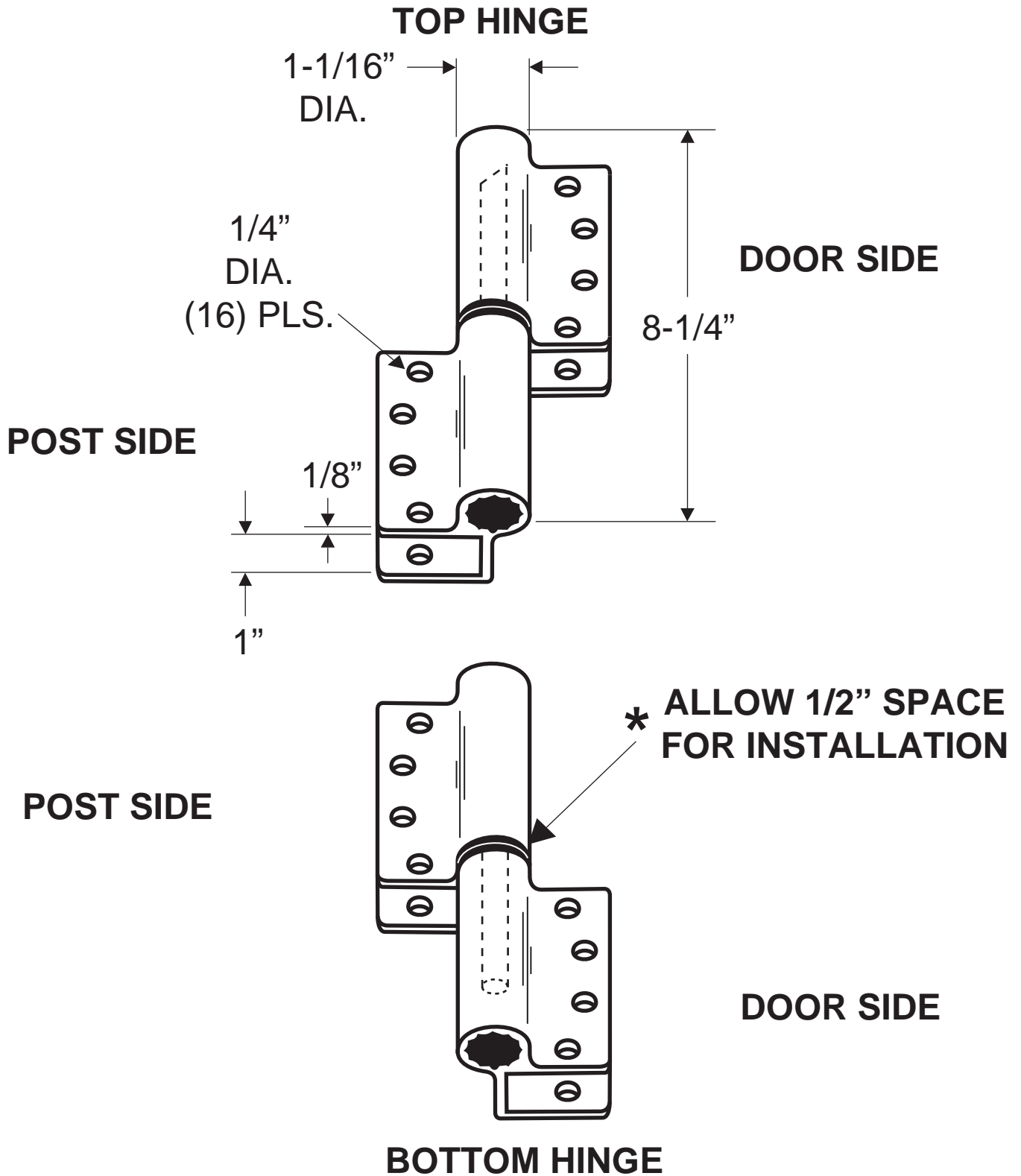

Inswing Strike & Latch Install

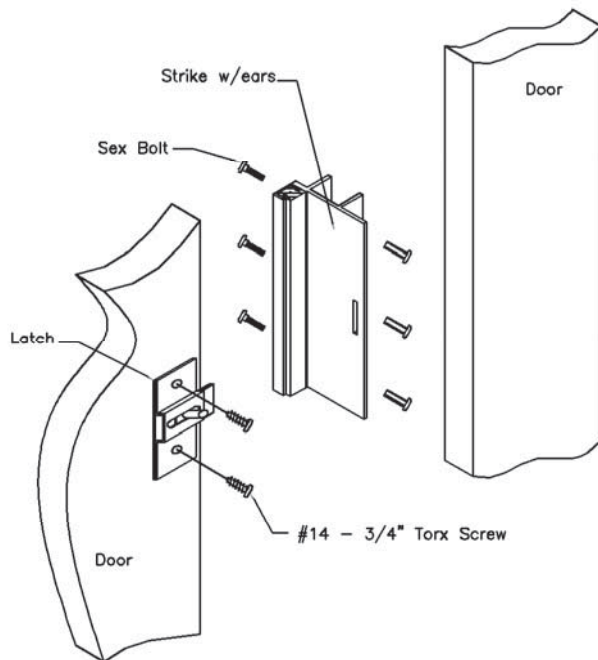

1. Center the strike on the pilaster 38" from the floor.
2. Using the strike as a template mark the holes.
3. Drill 1/4" holes.
4. Attach the strike using the Sex Bolts.
5. Center the door latch with the strike.
6. Mark and drill 3/16" holes 3/4" deep.
4. Attach the latch using the 3/4" Torx Screw.

Inswing Strike & Latch Install

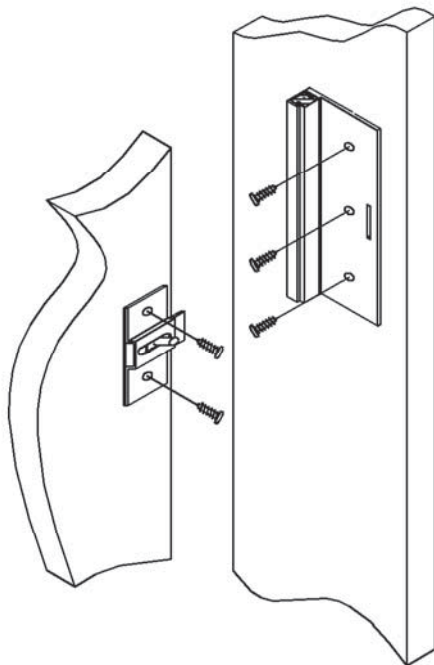

1. Locate the strike on the pilaster 38" from the floor.
2. Using the strike as a template mark the holes.
3. Drill 3/16" holes 3/4" deep.
4. Attach the strike using the #10-1" flat head screws.
5. Center the door latch with the strike.
6. Mark and drill 3/16" holes 3/4" deep.
4. Attach the latch using the 3/4" Torx Screw.

Outswing Strike w/ Ears

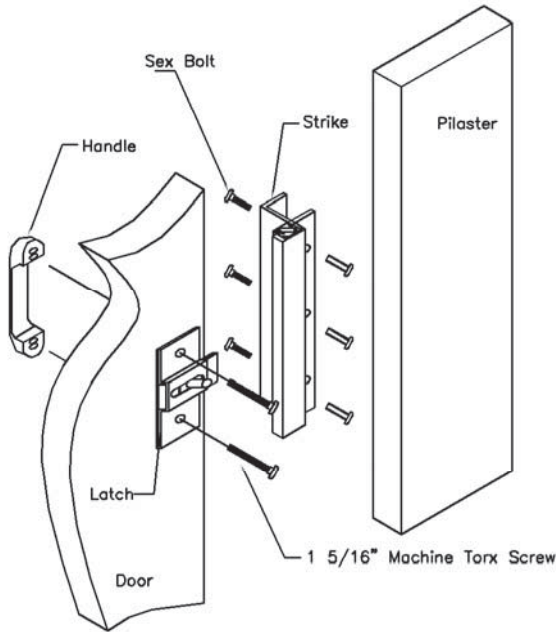

1. Center the strike on the pilaster 38" from the floor.
2. Using the strike as a template mark the holes.
3. Drill 1/4" holes.
4. Attach the strike using the Sex Bolts
5. Center the door latch with the strike.
6. Mark and drill 1/4" holes.
4. Attach the latch and handle using the 1 5/16" Machine Torx Screw.

Outswing Strike (surface mount)

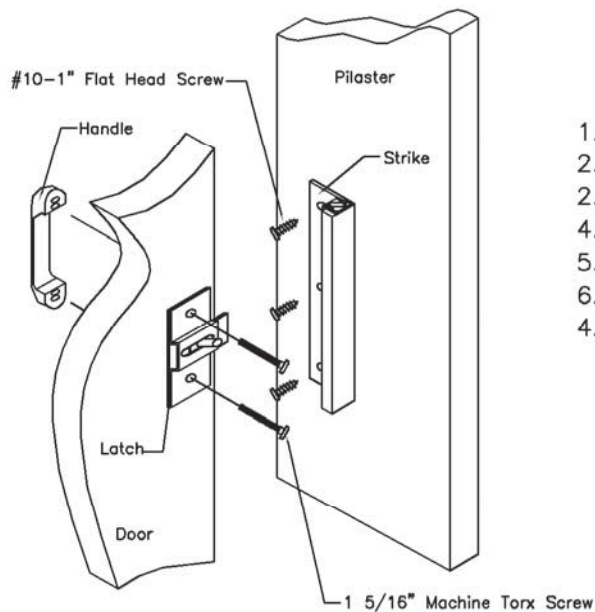

1. Center the strike on the pilaster 38" from the floor.
2. Using the strike as a template mark the holes.
2. Drill 3/16" holes 3/4" deep.
4. Attach the strike using the #10-1" flat head screws.
5. Center the door latch with the strike.
6. Mark and drill 1/4" holes.
4. Attach the latch and handle using the 1 5/16" Machine Torx Screw.

Inswing Strike (w/o ear)

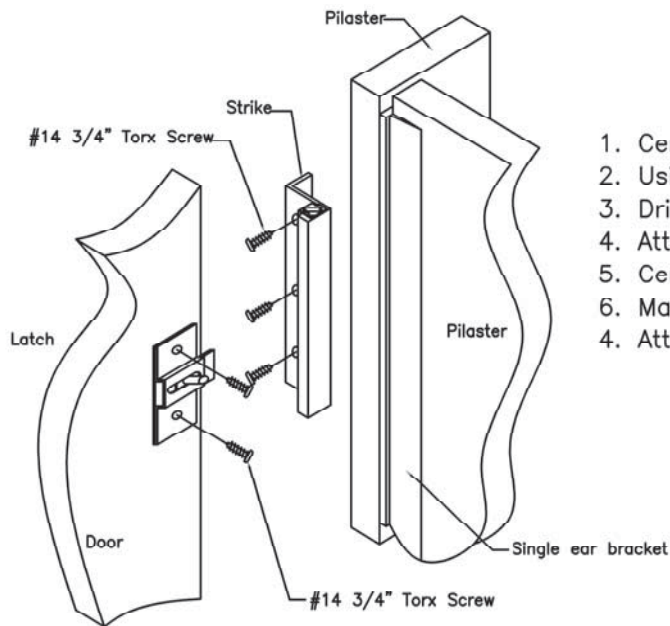

1. Center the strike on the pilaster 38" from the floor.
2. Using the strike as a template mark the holes.
3. Drill 1/4" holes.
4. Attach the strike using the 3/4" Torx Screw.
5. Center the door latch with the strike.
6. Mark and drill 3/16" holes 3/4" deep.
4. Attach the latch using the 3/4" Torx Screw.

Miscellaneous Parts Install

Coat Hook Install

1. Center the hook 3" from the top and side edge of the door.
2. Mark the hole locations and drill 3/16" pilot holes 3/4" deep.
3. Attach the hook using #10-3/4" Torx Screws.

Wall Stop (on door)

1. Center the door stop 3" from the bottom and side edge of the door.
2. Mark the hole locations and drill 3/16" pilot holes 3/4" deep.
3. Attach the stop using #14-3/4" Torx Screws.

Wall Stop (on wall)

1. Center the door stop 17" above the floor and 3" from the door edge when opened.
2. Mark the hole locations and drill 5/16" holes and install plastic anchors.
3. Attach the stop using #14-2 1/2" Torx Screws.